

# Developing Custom CAD Tools with FeatureScript

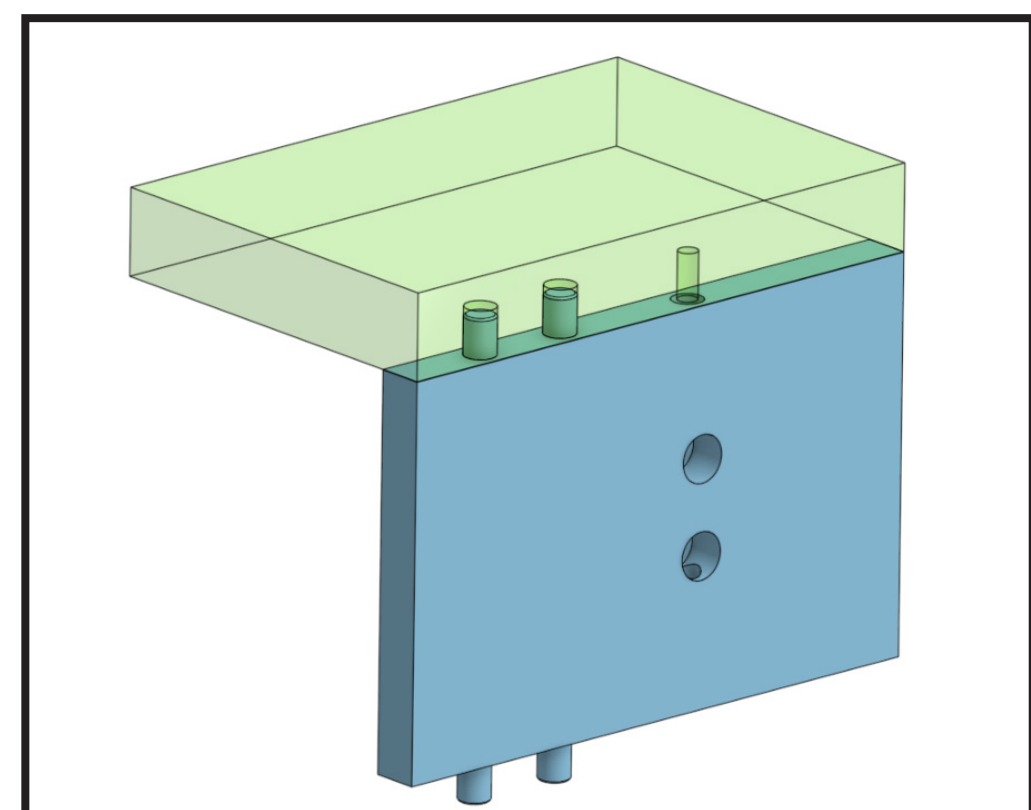

FeatureScript is the modeling language that powers Onshape. For the first time, Onshape is exposing this language to users, empowering them to create their own custom CAD tools. The Onshape SCOPE team collaborated with professional Onshape customers to create personalized Features that improve their design workflow. The team contributed to the new FeatureScript community, providing feedback and examples that will pave the way for aspiring FeatureScript developers.

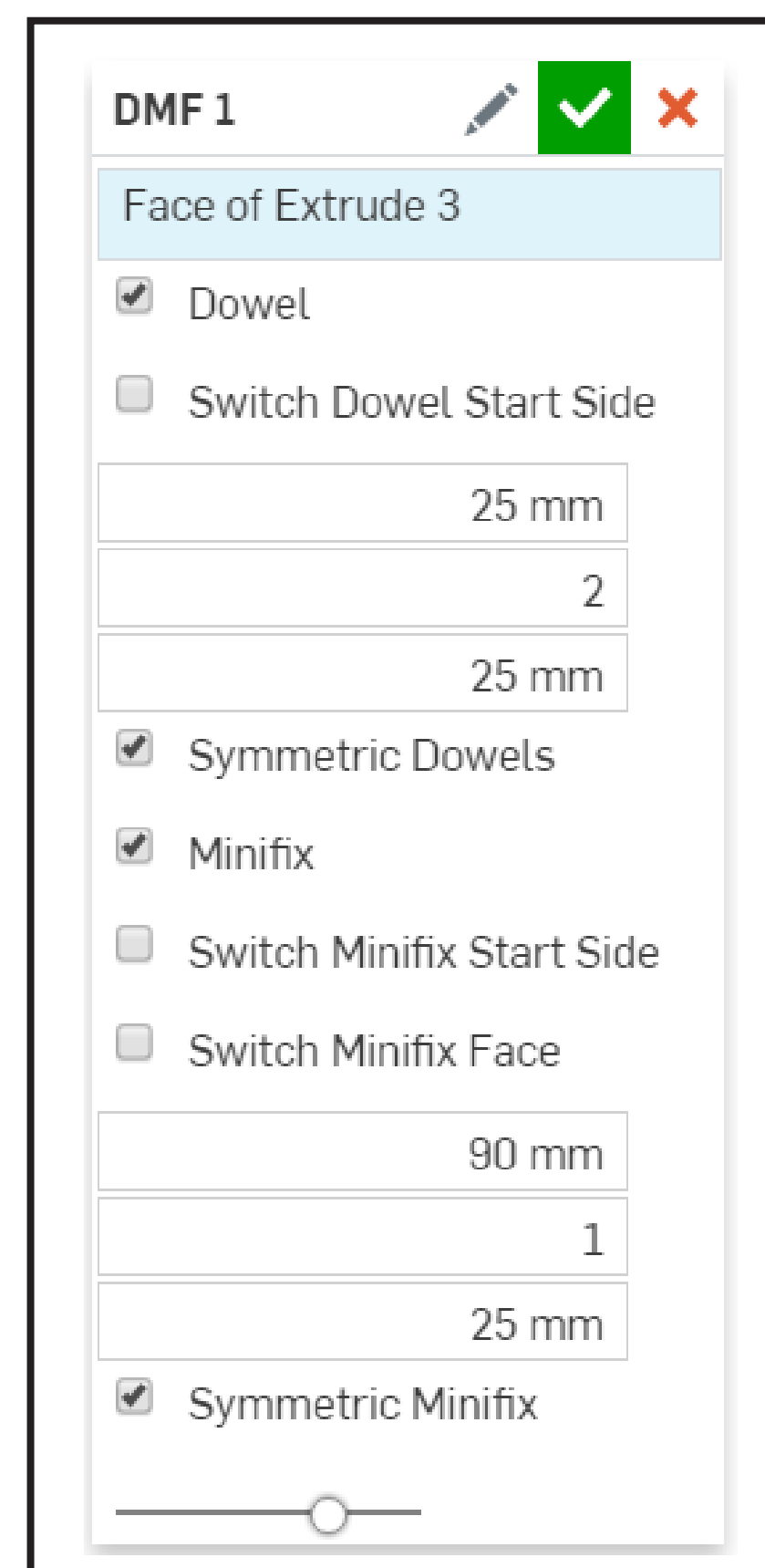
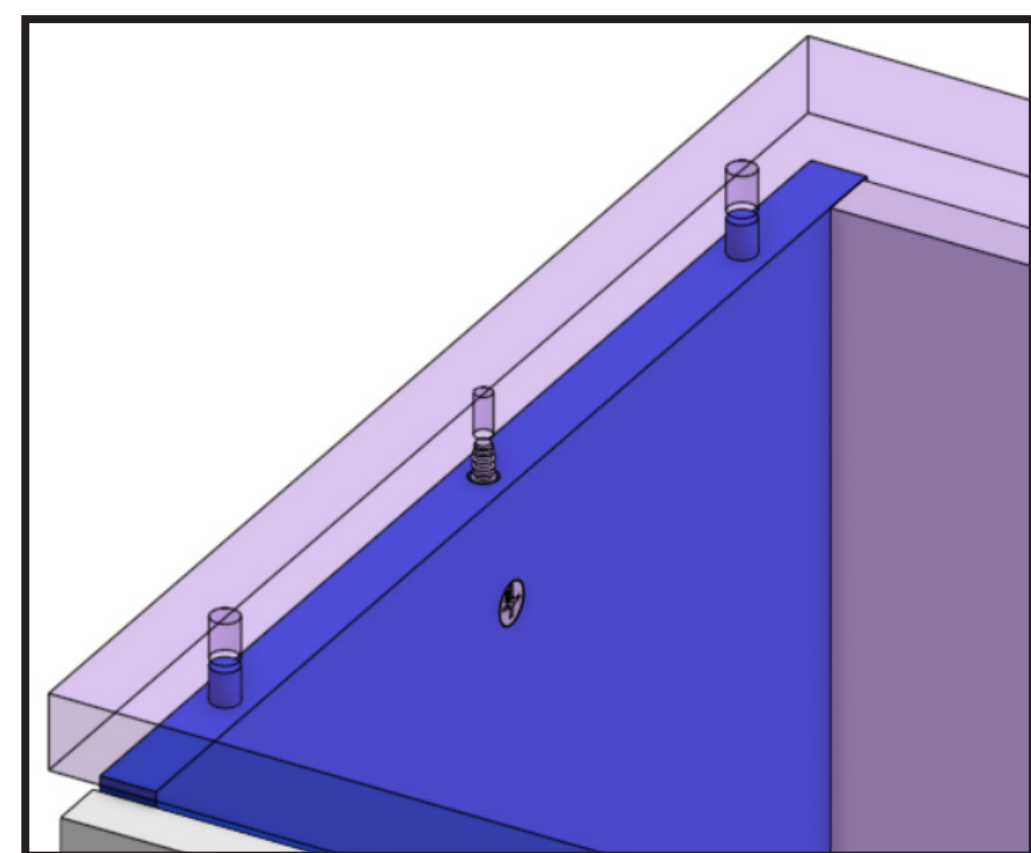

The team worked with an Onshape user who owns a furniture business to develop a feature that creates fastener geometry. This owner designs his own furniture, spending hours creating and inserting fasteners into his pieces. Two of the most common fasteners are dowels and minifixes. The DMF Feature allows the designer to select a fastener type, quantity, spacing, and location with just a few clicks.

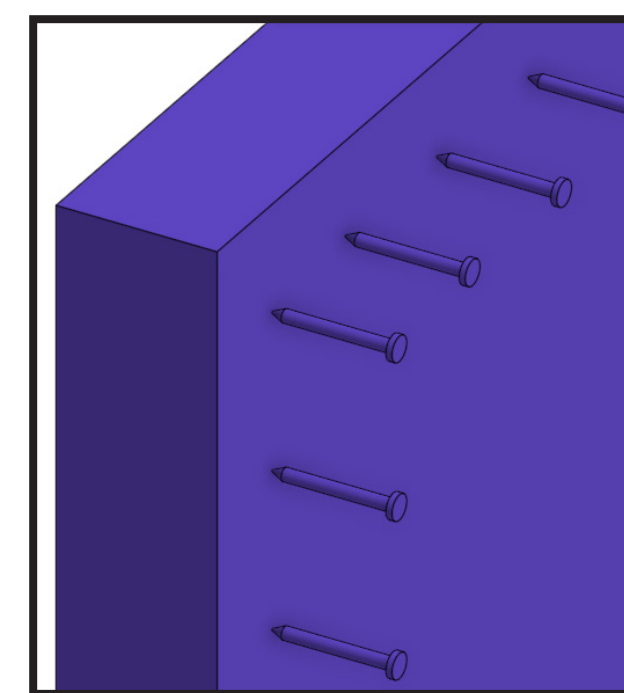

The Hinge Holes Feature allows the furniture designer to create hinge geometry in just a few clicks.

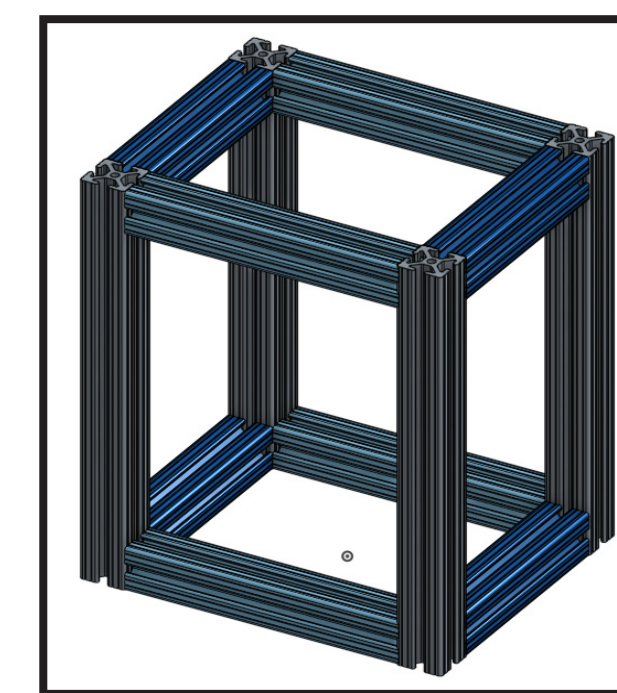

The Extrude Profile Feature makes it easy for the mechanical engineer to extrude, cut, and more using predefined profiles.

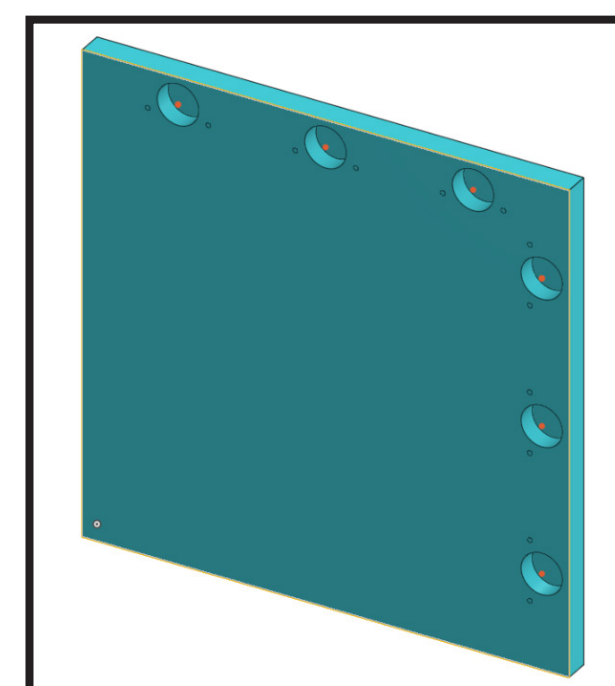

The Nails Feature allows the furniture designer to quickly input nails along the edges of a selected face.

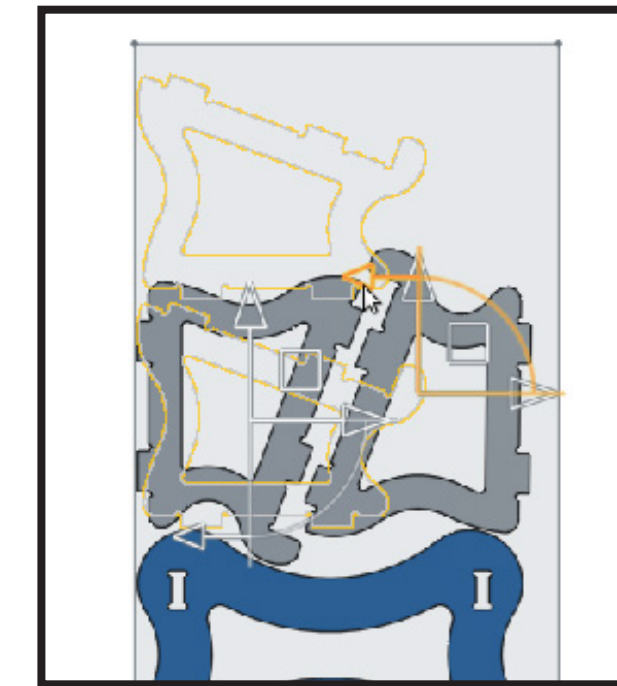

The Manipulator Transform Feature lets the mechanical engineer quickly adjust laid-out parts.

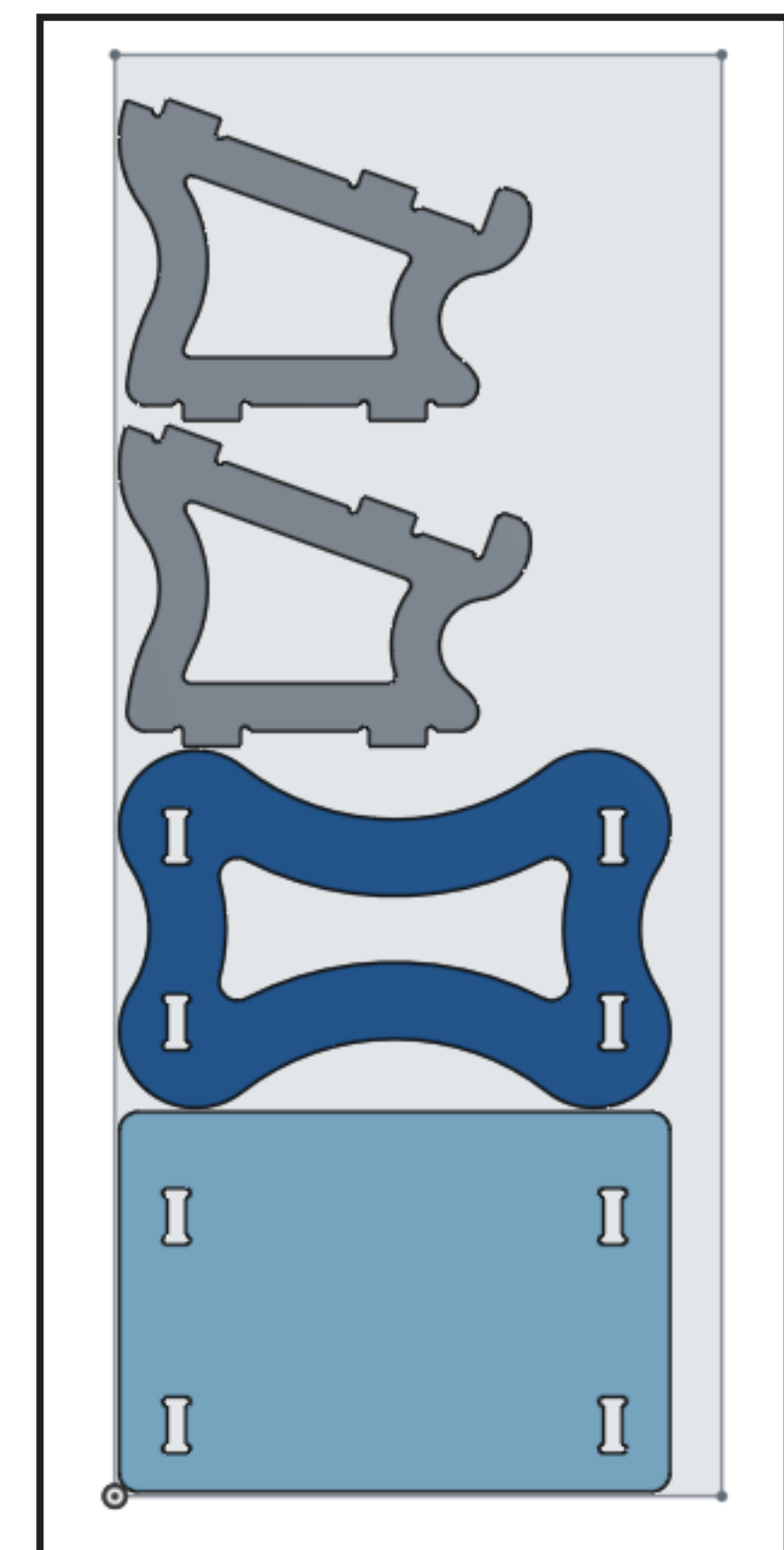
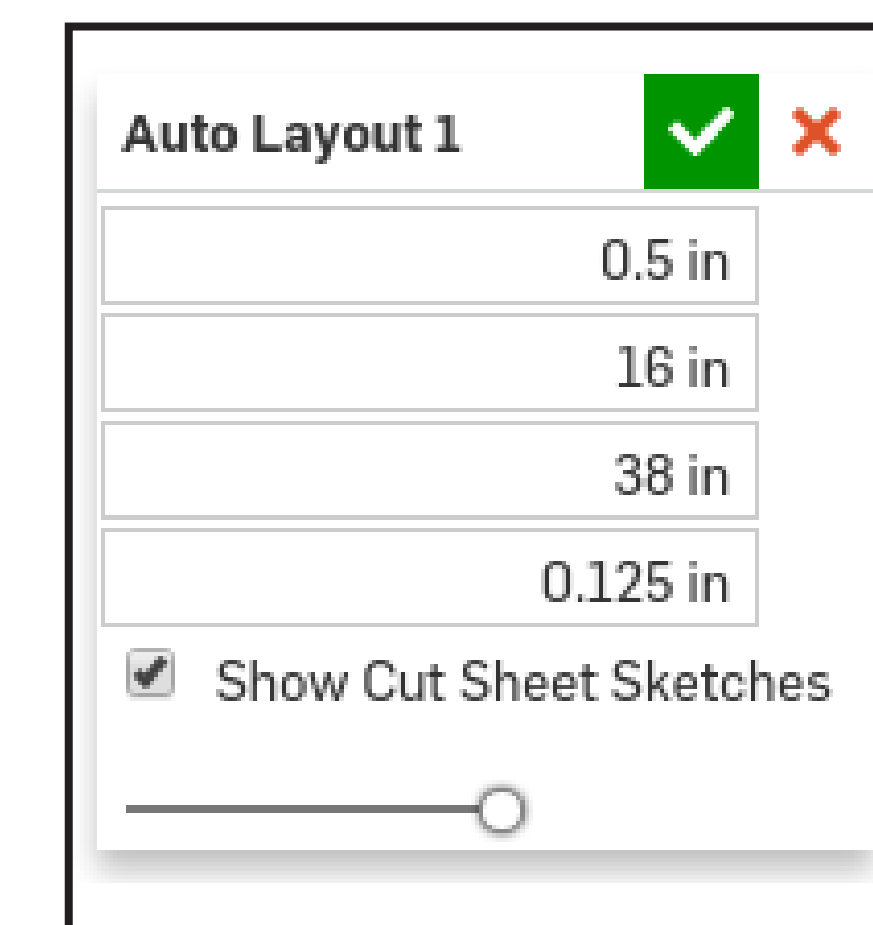
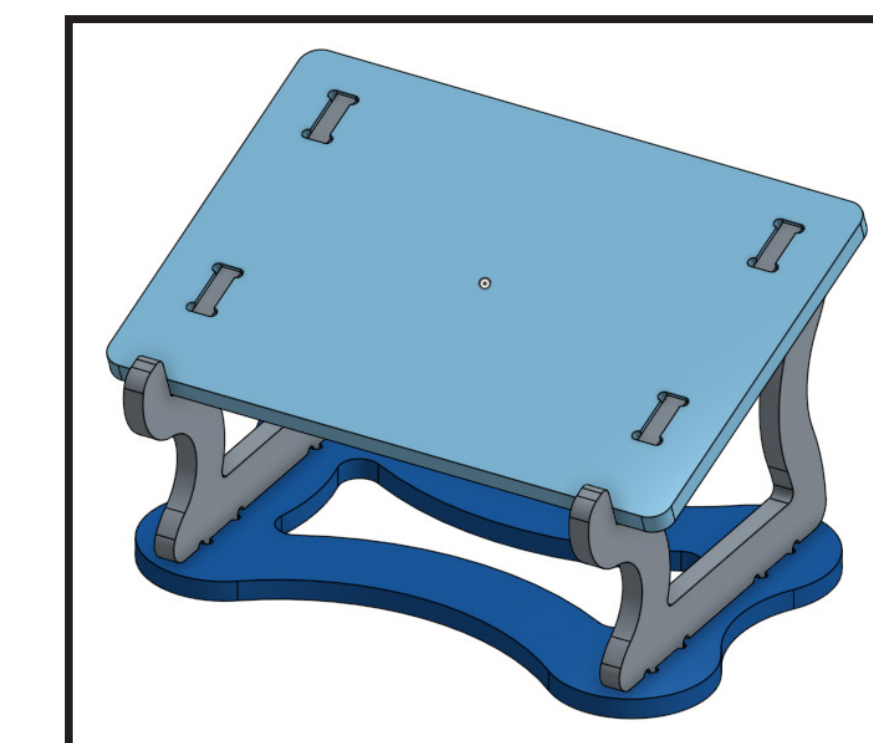

The team worked with a mechanical engineer who frequently uses laser cutting as a prototyping technique. The process of preparing cut sheets for laser cutting is tedious and time-consuming. The team developed the Auto Layout Feature, which places parts that match a specified thickness into a cut sheet layout with a single click using a binary tree bin-packing algorithm.



**Olin College**  
of Engineering  
**SCOPE**

SCOPE Team  
Lauren Froschauer  
Jacob Kingery  
Marena Richardson  
Amanda Sutherland  
Emily Wang

Faculty Advisor  
Ben Hill  
  
Onshape Liaison  
Kevin O'Toole

Onshape Team  
Scott Harris  
Kevin O'Toole  
Ilya Baran  
John Carr  
Kori Ryter  
Lana Saksonov

